



TECHNIKA

Shut-off dampers

ASUR/ASUP



Description

Shut-off dampers are used to install a ventilation system in buildings with spiral ducts. The opening angle α of the damper can be adjusted from 0° to 90° degrees.

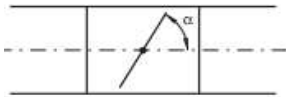

The damper on the flap has a sealing gasket, tightness is class 2 according to test standard LST EN 1751. Damper can be used as regulating damper as well. The position of the handle is fixed with screws. Round shut-off valves made of aluminium profiles and galvanized sheet steel with a zinc content of 275 g / m² - corrosion class C2 / C3 (L) according to LST EN ISO 12944 standard. Dampers is made with double seal gasket EPDM with self-slip material inside. Tightness class C according to LST EN 1506 and LST EN 12237. The dampers can be used at temperatures from -45 to +85 °C with appropriate insulation. The maximum permissible absolute humidity inside and outside the air stream is 18 g/kg.

Ordering code

..... ASUR800800-800
 Galvanized steel -
 Manual - ASUR
 With actuator - ASUP
 Size

Sample: ASUR800800-800 – made of aluminium shut-off damper, diameter 800 mm, with rectangular casing inside dimensions 800x800 mm.

Dimensions

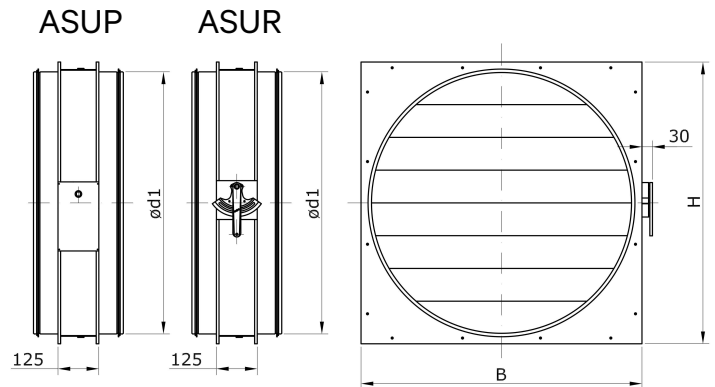

Ød1 [mm]	B [mm]	H [mm]	Mass [kg]	Tightness class when damper blade is in closed position
630	750	750	11,5	2
710	750	750	12,3	2
800	850	850	16,1	2
900	950	950	21,3	2
1000	1050	1050	25,7	2
1250	1350	1350	40,0	2

Technical data	630-1250
The manual damper has locking screws	x
The manual valve has a reinforced opening mechanism, lever and axle	x
Damper flap made of anodized aluminium profile with EPDM gasket on the flaps	x
Damper with hidden axis and aerodynamic flaps	x
The damper may be provided with an actuator mounting base plate	x

Technical data

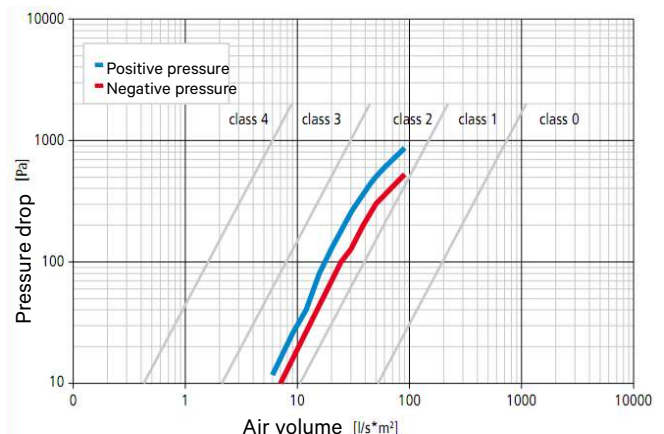



TECHNIKA

Shut-off dampers

ASUR/ASUP

Technical data

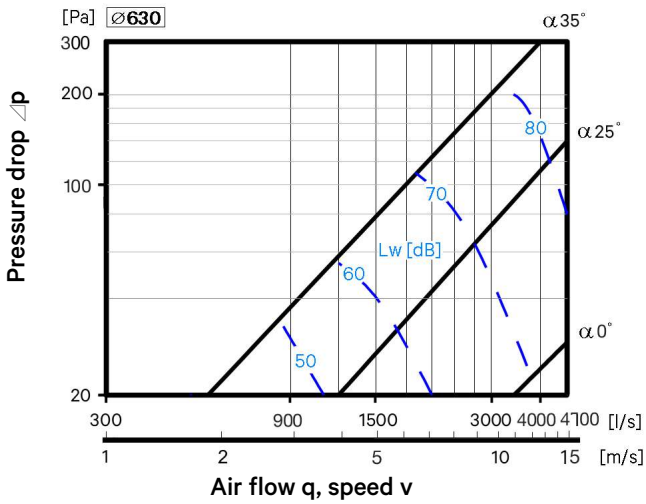

Technical data

