

# Transitions

FPS



## Description

Transitions are only used to supply or extract air from the premises and are not intended for the transport of particulate matter in the air. Transitions distribute air movement evenly when it is necessary to switch between different dimensions of connection. The products can be made of: galvanized steel sheet - corrosion class C3-L / C2-M; sheet with aluminium zinc coating - corrosion class C4-M / C3-H; stainless steel sheet AISI 304 (1.4301) or AISI 316L (1.4404) - corrosion class C5. Standard transitions joint tightness class B according to LST EN 1507. Products of higher C tightness class are also available on request. Transitions can be used at temperatures from -45 to +85 °C with appropriate insulation. The maximum permissible absolute humidity inside the air stream and outside is 18 g / kg. Protective films, that ensure cleanliness, are placed at the customer's request when ordering. For other dimensions and materials, please contact UAB „MKTechnika“ sales offices.

## Ordering code

..... FPS500300/100100-1-300
Galvanized steel - AISI 304 – NP AISI 316L – 316NP
Product
Size
Smallest dimension w ir h, mm
Number of position
Length L, mm

Sample: FPS500300/100100-1-300 – made of galvanized steel transition, dimensions WxH- 500x300 mm, to wxh – 100x100 mm, centre position 1, length 300 mm.

## Dimensions

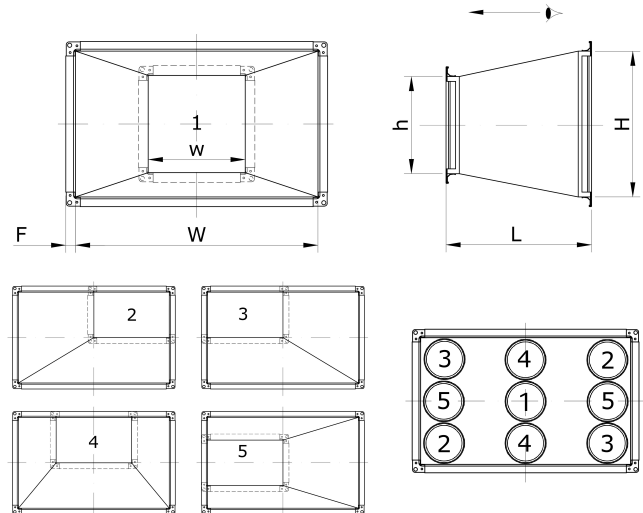

	W or w [mm]	H or h [mm]
Minimum dimensions	100	100
Maximum standard dimensions	2100	2100
Flange F20	Up to 1499	Up to 1499
Flange F30	1500-2100	1500-2100

Passage length L depends on the chosen dimensions W, H, h, w and the optimum is chosen to minimize air pressure drop. If required, the length L is determined by the customer as required in the product.

## Technical data

Transitions flanges come with a sealing gel. The gel meets the requirements of VDI 6022 standard. The pressure losses of the rectangular system are calculated using data from round ducts. Calculate the cross area and take the nearest smaller cross area of the circular duct.

Weight formula [kg] (galvanized steel)	W [mm]	H [mm]
$m[\text{kg}] = 6,7 \cdot (W[\text{m}] \cdot L[\text{m}] + H[\text{m}] \cdot L[\text{m}]) + 2,2(W[\text{m}] + H[\text{m}])$	Up to 1000	Up to 1000
$m[\text{kg}] = 8 \cdot (W[\text{m}] \cdot L[\text{m}] + H[\text{m}] \cdot L[\text{m}]) + 2,2(W[\text{m}] + H[\text{m}])$	From 1001 up to 1400	Up to 1000
$m[\text{kg}] = 8 \cdot (W[\text{m}] \cdot L[\text{m}] + H[\text{m}] \cdot L[\text{m}]) + 2,5(W[\text{m}] + H[\text{m}])$	From 1001 up to 1400	From 1001 up to 1400
$m[\text{kg}] = 9,5 \cdot (W[\text{m}] \cdot L[\text{m}] + H[\text{m}] \cdot L[\text{m}]) + 2,8(W[\text{m}] + H[\text{m}])$	From 1401 up to 2100	From 1001 up to 1400
$m[\text{kg}] = 9,5 \cdot (W[\text{m}] \cdot L[\text{m}] + H[\text{m}] \cdot L[\text{m}]) + 2,8(W[\text{m}] + H[\text{m}])$	From 1401 up to 2100	From 1401 up to 2100



# Transitions

FPS

## Technical data

When operating the duct system it is very important to observe the maximum allowable vacuum pressure. It varies depending on the size of the duct. Also, the stability of the entire system has a smooth and even duct surface that can be damaged during transportation or installation, which is why it is important to protect the ducts and other elements from damage. We recommend that you observe the maximum allowable pressures Pa in the table when selecting the duct system. For pressures close to the critical limit, we recommend the use fine ducts to prevent possible duct compression or swelling in the system.

Maximum allowable system pressure [Pa]	W [mm]	H [mm]
1000	Up to 1000	Up to 1000
1000	From 1001 up to 1400	Up to 1000
1300	From 1001 up to 1400	From 1001 up to 1400
1500	From 1401 up to 2100	From 1001 up to 1400
1500	From 1401 up to 2100	From 1401 up to 2100