

Diffusers

PDVS



Description

Diffusers are installed in ceiling or wall structures by screwing them together with the duct. PDVS is supply air diffuser.

Circular diffusers are made of sheet steel and painted in RAL 9016 color. The air flow is regulated by turning the inner part of the diffuser. The amount of air depends on the clearance between the pickup plate and the housing. The diffuser has a low noise due to the smooth internal surfaces. Quick installation - the diffuser is mounted into the frame with a rotational movement without any fixing screws. The diffusers are supplied with a mounting ring for the duct.

Ordering code

Product	PDVS200
Size	

Sample: PDVS200 – steel diffuser, diameter 200 mm, painted in RAL9016 colour.

Dimensions

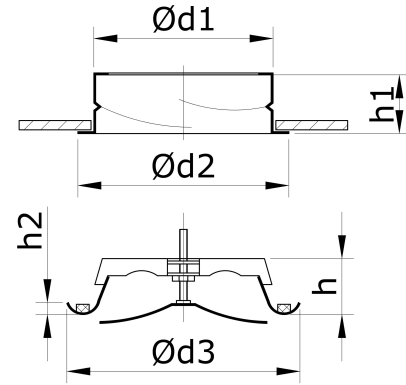

PDVS	Ød1 [mm]	Ød2 [mm]	Ød3 [mm]	h [mm]	h1 [mm]	h2 [mm]	Mass [kg]
100	98	125	137	55	50	10	0,19
125	123	150	164	55	50	10	0,31
160	159	185	212	55	50	10	0,47
200	198	225	248	55	50	10	0,66
250	248	290	305	75	50	10	0,88

Technical data

Total A-weighted sound power level L_{WA} dB(A) in octaves, obtained by mathematically subtracting factor k to A-weighted sound power level L_{WA} dB(A) shown in diagrams and depends of diffuser opening dimension a in mm.

$$L_{WA_{okt}} = L_{WA} - k$$

PDVS	Sound power coefficient k at centre frequency							
	63 Hz	125 Hz	250 Hz	500 Hz	1 kHz	2 kHz	4 kHz	8 kHz
100	-	2	2	-1	-6	-14	-25	-37
125	-	2	4	-2	-7	-14	-25	-37
160	-	5	4	-3	-9	-14	-26	-36
200	-	5	5	-2	-8	-16	-24	-36
250	-	5	5	-3	-7	-16	-25	-35
Tolerance	±6	±3	±2	±2	±2	±2	±2	±3

PDVS	Sound attenuation, dB at centre frequency							
	63 Hz	125 Hz	250 Hz	500 Hz	1 kHz	2 kHz	4 kHz	8 kHz
100	22	16	11	8	6	6	3	6
125	20	15	9	6	4	3	3	5
160	18	13	8	5	4	4	5	6
200	17	11	7	6	6	5	6	6
250	18	12	9	7	7	6	7	5
Tolerance	±6	±3	±2	±2	±2	±2	±2	±3



TECHNIKA

Diffusers

PDVS

