

# Rectangular fire damper with actuator

UV(P)



## Description

Fire dampers are designed for use in general ventilation installation, in points of penetration of these installations through building partitions. During fire, they allow to maintain fire resistance of the building partition through which ventilation and air conditioning ducts run. The blade of the damper is made of filled heat-resistant material. Casing tightness class is C according to LST EN 1751. The dampers are tested and classified in accordance with standards LST EN 1366-2 and LST EN 13501-3 with allowable negative pressures up to 300 Pa. Dampers are CE marked using standard LST EN 15650. These types of dampers can be installed in flexible walls, solid walls and ceilings of concrete or porous silicate blocks. The dampers UV (P) have an electric actuator with a sensor that activates when the temperature rises to 72°C and closes with a closing spring. The damper have integrated end position contacts in the actuator. In the normal position, the blade of the damper is open when the damper is triggered in case of fire, the blade closes automatically. The fire resistance is EI120(ve, ho i<-> o)S. The dampers are made of galvanized sheet steel with a zinc content of 275 g/m<sup>2</sup> - corrosion class C2/C3 (L) according to LST EN ISO 12944 standard. Can also be manufactured from other materials, such as stainless steel sheet AISI 304 (1.4301) or, AISI 316L (1.4404) - corrosion class C5. The damper is sealed in the duct system by sealing with seals such as the standard ventilation duct system. The damper can be used at temperatures from -20 °C to + 50 °C. The maximum permissible absolute humidity inside and outside the air stream is 18 g/kg. The smoke damper must not be used in a system that carries solids.

## Dimensions

200x200 - 800x400

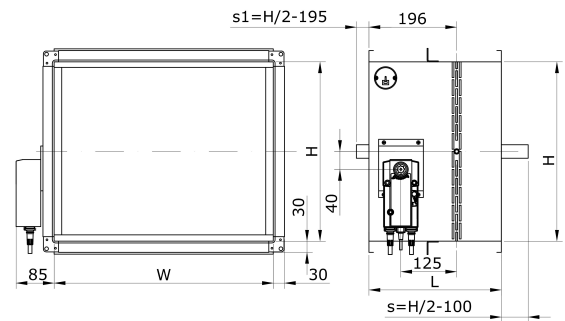

800x400 - 1500x1500

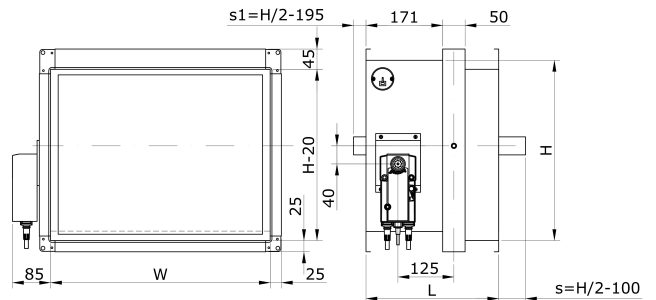

W [mm]	H [mm]	s [mm]	s1 [mm]	L [mm]
200 - 1500	200	-	-	296
200 - 1500	300	50	-	296
200 - 1500	400	100	5	296
200 - 1500	500	150	55	296
200 - 1500	600	200	105	296
200 - 1500	700	250	155	296
200 - 1500	800	300	205	296
200 - 1500	900	350	255	296
200 - 1500	1000	400	305	296
200 - 1500	1100	450	355	296
200 - 1500	1200	500	405	296
200 - 1500	1300	550	455	296
200 - 1500	1400	600	505	296
200 - 1500	1500	650	555	296

## Ordering code

..... UV400200P230

Galvanized steel -

AISI 304 - NP

AISI 316L - 316NP

Product

Size

Actuator 24V - P24, 230V - P230

Sample: UV400200P230 - made of galvanized steel fire damper, dimensions WxH - 400x200 mm, fire resistance EI120S, with actuator.

# Rectangular fire damper with actuator

UV(P)

## Technical data

Fire dampers UV are available in two design types. The smaller dimensions up to WxH - 800x400 mm are made of a solid perforated body type FID C, while the larger dimensions are made of a dual body with a heat-resistant material separated between, type FID S.

	W [mm]	H [mm]
Minimum dimension	200	200
Maximum dimension	1500	1500
Standard step, mm	100	
Non standard step up to order, mm	50	
Maximum cross section area of damper, m <sup>2</sup>	1,8	
Weight formula: m[kg]=33*W[m]*H[m]+10*(W[m]+H[m]) *	From 200 up to 800	From 200 up to 400
Weight formula" m[kg]=34*W[m]*H[m]+12*(W[m]+H[m]) *	From 801 up to 1500	From 401 up to 1500

\* need to add the weight of actuator ~ 1,5 kg

Fire resistance classification according LST EN 13501-3

		EI 120 S 300 [Pa]	
<b>Solid wall</b>	<b>EI 120 S – installation in solid masonry wall</b>	Wet installation 200x200 - 1500x1500**	
	Minimum thickness of the wall – 110* mm		
	Minimum density of the wall – 550 kg/m <sup>3</sup>		
	Concrete or cement lime masonry mortar. *Dampers from 801x401 mm, and if wall 110 mm, additional use 12.5 mm gypsum board 100 mm width around the damper on both sides. If wall 125 mm without additional board.		
	ve i<-> o, distance between dampers 200 mm, to wall corner 75 mm		
<b>Flexible wall</b>	<b>EI 120 S – installation in flexible wall</b>	Wet installation 801x401 - 1500x1500**	
	Minimum thickness of the wall – 125 mm		
	Minimum density of mineral wool inside the wall – 80 kg/m <sup>3</sup>		
	Plaster filler fire resistance class A1		
		ve i<-> o, distance between dampers 200 mm, to wall corner 75 mm	
	<b>EI 120 S – installation in flexible wall</b>	Wet installation 200x200 - 800x400	
	Minimum thickness of the wall – 125 mm		
	Minimum density of mineral wool inside the wall – 80 kg/m <sup>3</sup>		
Plaster filler fire resistance class A1, additional use 12.5 mm gypsum board 100 mm width around the damper on both sides.			
	ve i<-> o, distance between dampers 200 mm, to wall corner 75 mm		
<b>Ceiling</b>	<b>EI 120 S – installation in solid ceiling</b>	Wet installation 200x200 - 1500x1500**	
	Minimum thickness of the ceiling – 150 mm		
	Minimum density of the ceiling – 650 kg/m <sup>3</sup>		
	Plaster filler fire resistance class A1 or cement mortar		
	ho i<-> o		

\*\* Maximum allowable cross section area of fire damper 1,8 m<sup>2</sup>.

Fire damper installation outside fire partition

		EI 120 S 300 [Pa]
<b>Solid wall</b>	<b>EI 120 S – installation outside the solid wall with mineral wool boards</b>	Wet installation 200x200 - 1500x1500**
	Minimum thickness of the wall – 120 mm	
	Minimum density of the wall – 550 kg/m <sup>3</sup>	
	Concrete or cement lime masonry mortar - the damper must be fitted to the duct and the entire system covered with materials of class EI 120S or better. Eg: stone wool 140 kg/m <sup>3</sup> with gypsum filler. Gaps fill for extra protection with mineral wool, density - 80 kg/m <sup>3</sup> . In addition, use gypsum filler grade A1.	
	ve i<-> o distance between dampers 200 mm, to wall corner 75 mm	

\*\* Maximum allowable cross section area of fire damper 1,8 m<sup>2</sup>.



TECHNIKA

# Rectangular fire damper with actuator

UV(P)

## Technical data

WxH – air duct dimensions [mm], v – speed [m/s],  $S_{ort}$  – duct cross section area [m<sup>2</sup>],  $S_{ps}$  – damper cross section area [m<sup>2</sup>], Q – air flow [m<sup>3</sup>/h], dp – pressure drop [Pa],  $L_{wa}$  – sound power [dB].

### EI 120 S

WxH [mm]	$S_{ort}$ [m <sup>2</sup> ]	$S_{ps}$ [m <sup>2</sup> ]	v [m/s]	Q [m <sup>3</sup> /h]	dp [Pa]	$L_{wa}$ [dB]
200 x 200	0,040	0,033	4	468	8	26
			6	702	14	36
			8	936	24	44
			10	1170	38	50
400 x 200	0,080	0,065	4	936	5	27
			6	1404	12	38
			8	1872	22	45
			10	2340	34	51
800 x 200	0,160	0,130	4	1872	2	20
			6	2808	5	30
			8	3744	10	38
			10	4680	15	43
1000 x 200	0,20	0,146	4	2102	7	34
			6	3154	15	44
			8	4205	28	52
			10	5256	43	58
400 x 400	0,160	0,145	4	2088	3	23
			6	3132	7	34
			8	4176	12	41
			10	5220	19	47
800 x 400	0,32	0,290	4	4176	2	18
			6	6264	14	28
			8	8352	6	36
			10	10440	10	42
1000 x 400	0,40	0,346	4	4982	4	30
			6	7474	10	42
			8	9965	18	50
			10	12456	29	56
1200 x 400	0,480	0,415	4	5979	4	31
			6	8968	9	42
			8	11958	16	49
			10	14947	25	55
800 x 600	0,480	0,437	4	6290	4	31
			6	9435	9	42
			8	12580	16	50
			10	15725	26	56
1000 x 600	0,600	0,546	4	7862	3	29
			6	11794	8	41
			8	15725	14	49
			10	19656	23	55
1200 x 600	0,720	0,655	4	9435	3	29
			6	14152	7	41
			8	18870	12	48
			10	23587	20	54

## Technical data

### EI 120 S

WxH [mm]	$S_{ort}$ [m <sup>2</sup> ]	$S_{ps}$ [m <sup>2</sup> ]	v [m/s]	Q [m <sup>3</sup> /h]	dp [Pa]	$L_{wa}$ [dB]
800 x 800	0,640	0,597	4	8594	3	29
			6	12891	8	42
			8	17188	14	49
			10	21485	22	55
1000 x 800	0,800	0,746	4	10742	3	30
			6	16114	7	41
			8	21485	12	48
			10	26856	19	54
1200 x 800	0,960	0,895	4	12891	2	26
			6	19336	6	40
			8	25782	10	47
			10	32227	16	53
1000 x 1000	1,000	0,946	4	13622	2	26
			6	20434	6	40
			8	27245	11	48
			10	34056	17	54
1200 x 1000	1,200	1,135	4	16347	2	27
			6	24520	5	39
			8	32694	9	46
			10	40867	14	52
1200 x 1200	1,440	1,375	4	19803	2	27
			6	29704	4	36
			8	39606	8	45
			10	49507	13	52