

Circular fire dampers with fuse element

UV



Description

Fire dampers are designed for use in general ventilation installation, in points of penetration of these installations through building partitions. During fire, they allow to maintain fire resistance of the building partition through which ventilation and air conditioning ducts run. The blade of the damper is made of filled heat-resistant material. Casing tightness class is C according to LST EN 1751. The dampers are tested and classified in accordance with standards LST EN 1366-2 and LST EN 13501-3 with allowable negative pressures up to 300 Pa. Dampers are CE marked using standard LST EN 15650. These types of dampers can be installed in flexible walls, solid walls and ceilings of concrete or porous silicate blocks. Dampers has manual triggering mechanism with integrated spring and temperature sensor of 74°C. The damper can be ordered with integrated end position contacts in the trigger mechanism. In the normal position, the blade of the damper is open when the damper is triggered in case of fire, the blade closes automatically with spring inside. The fire resistance is EI120(ve, ho i<-> o)S and damper UVEI60 is EI60(ve, ho i<-> o)S. The dampers are made of galvanized sheet steel with a zinc content of 275 g/m² - corrosion class C2/C3 (L) according to LST EN ISO 12944 standard. Can also be manufactured from other materials, such as stainless steel sheet AISI 304 (1.4301) or, AISI 316L (1.4404) - corrosion class C5. The damper is sealed in the duct system by sealing with seals such as the standard ventilation duct system. The damper can be used at temperatures from -20 °C to + 50 °C. The maximum permissible absolute humidity inside and outside the air stream is 18 g/kg. The smoke damper must not be used in a system that carries solids.

Dimensions

Ød - 100-315

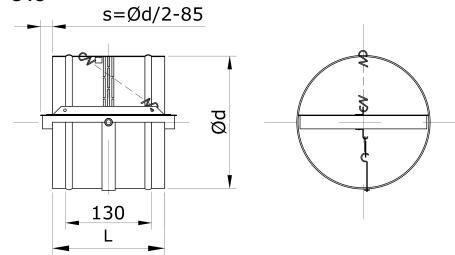

Ød - 400-630

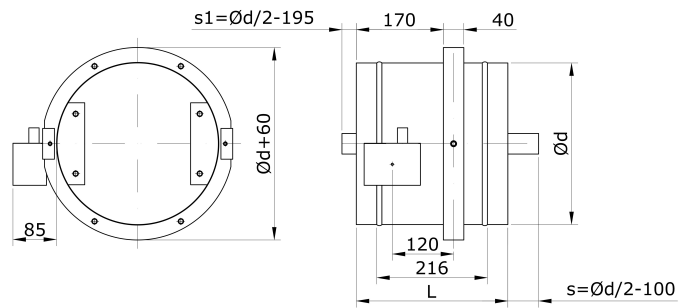

Ød _{nom} [mm]	Ød [mm]	s [mm]	s1 [mm]	L [mm]	Mass [kg]	EI 120 S	EI 60 S
100	98	-	-	170	0,7	+	+
125	123	-	-	170	0,9	+	+
160	158	-	-	170	1,2	+	+
200	198	15	-	170	1,7	+	+
250	248	40	-	170	2,1	+	+
315	313	72,5	-	170	2,6	+	+
400	398	100	5	296	14	+	-
500	498	150	55	296	16	+	-
630	628	215	120	296	20	+	-

Ordering code

Galvanized steel - UV200EI60
AISI 304 - NP	
AISI 316L - 316NP	
Product	
Size	
EI120 - , EI60 - EI60	
Manual trigger mechanism	

Sample: UV200EI60 – made of galvanized steel manual fire damper, diameter 200 mm, fire resistance EI60.

Circular fire dampers with fuse element

UV

Technical data

Fire resistance classification according LST EN 13501-3

			EI 120 S 300 [Pa]	EI 60 S 300 [Pa]
Solid wall	EI 120 S – installation in solid masonry wall	Wet installation	Ø 100 – 315 Ø 400 – 630*	Ø 100 - 315
	Minimum thickness of the wall – 125 mm			
	Minimum density of the wall – 550 kg/m ³			
	Concrete or cement lime masonry mortar. Additional use 12.5 mm gypsum board 100 mm width around the damper on both sides. ve i<-> o, distance between dampers 200 mm, to wall corner 75 mm			
Flexible wall	EI 60 S – installation in flexible wall	Dry installation	-	Ø 100 - 315
	Minimum thickness of the wall – 125 mm			
	Minimum density of mineral wool inside the wall – 80 kg/m ³			
	Mineral wool 80 kg/m ³ and plaster filler fire resistance class A1 ve i<-> o, distance between dampers 200 mm, to wall corner 75 mm			
	EI 120 S – installation in flexible wall	Dry installation	Ø 100 - 315	Ø 100 - 315
	Minimum thickness of the wall – 125 mm			
	Minimum density of mineral wool inside the wall – 80 kg/m ³			
	Mineral wool 80 kg/m ³ and plaster filler fire resistance class A1 ve i<-> o, distance between dampers 200 mm, to wall corner 75 mm			
	EI 60 S – installation in flexible wall	Wet installation	-	Ø 100 - 315
	Minimum thickness of the wall – 125 mm			
	Minimum density of mineral wool inside the wall – 80 kg/m ³			
	Plaster filler fire resistance class A1 ve i<-> o, distance between dampers 200 mm, to wall corner 75 mm			
EI 120 S – installation in flexible wall	Wet installation	Ø 100 – 315 Ø 400 – 630*	Ø 100 - 315	
Minimum thickness of the wall – 125 mm				
Minimum density of mineral wool inside the wall – 80 kg/m ³				
Concrete or cement lime masonry mortar. Additional use 12.5 mm gypsum board 100 mm width around the damper on both sides. ve i<-> o, atstumas tarp sklendžių 200 mm , iki sienos kampo 75 mm				
Ceiling	EI 120 S – installation in solid ceiling	Wet installation	Ø 100 – 315 Ø 400 – 630	Ø 100 - 315
	Minimum thickness of the ceiling – 150 mm			
	Minimum density of the ceiling – 650 kg/m ³			
	Plaster filler fire resistance class A1 or cement mortar ho i<-> o			

Fire damper installation outside fire partition

			EI 120 S 300 [Pa]	EI 60 S 300 [Pa]
Solid wall	EI 120 S – installation outside the solid wall with mineral wool boards	Wet installation	Ø 100 – 315 Ø 400 – 630*	Ø 100 - 315
	Minimum thickness of the wall – 120 mm			
	Minimum density of the wall – 550 kg/m ³			
	Concrete or cement lime masonry mortar - the damper must be fitted to the duct and the entire system covered with materials of class EI 120S or better. Eg: stone wool 140 kg/m ³ with gypsum filler. Gaps fill for extra protection with mineral wool, density - 80 kg/m ³ . In addition, use gypsum filler grade A1. ve i<-> o distance between dampers 200 mm, to wall corner 75 mm			



TECHNIKA

Circular fire dampers with fuse element

UV

Technical data

$\varnothing d_{nom}$ – duct dimensions [mm], v – air speed [m/s], S_{ort} – duct cross section area [m²], S_{ps} – damper cross section area [m²], Q – air flow [m³/h], dp – pressure drop [Pa], L_{wa} – sound power [dB].

EI 120 S

$\varnothing d_{nom}$ [mm]	S_{ort} [m ²]	S_{ps} [m ²]	v [m/s]	Q [m ³ /h]	dp [Pa]	L_{wa} [dB]
100	0,0079	0,0064	2	46	3	16
			4	91	11	25
			6	137	20	33
			8	183	32	40
125	0,0123	0,0098	2	70	3	19
			4	141	10	27
			6	211	20	36
			8	281	33	42
160	0,0201	0,0169	2	122	1	16
			4	243	4	17
			6	365	9	28
			8	487	16	35
200	0,0314	0,0274	2	197	1	16
			4	395	5	21
			6	592	11	33
			8	789	20	40
250	0,0491	0,0391	2	281	2	17
			4	563	4	21
			6	844	7	27
			8	1125	10	33
315	0,0779	0,0653	2	470	2	18
			4	940	4	23
			6	1410	7	31
			8	1880	13	39
400	0,1256	0,1096	2	789	1	17
			4	1578	4	25
			6	2367	11	34
			8	3156	10	41
500	0,1963	0,1763	2	1269	1	18
			4	2538	4	24
			6	3807	8	33
			8	5076	15	40
630	0,3116	0,2864	2	2062	1	20
			4	4124	2	22
			6	6186	5	33
			8	8247	9	40

Technical data

EI 60 S

$\varnothing d_{nom}$ [mm]	S_{ort} [m ²]	S_{ps} [m ²]	v [m/s]	Q [m ³ /h]	dp [Pa]	L_{wa} [dB]
100	0,0079	0,0064	2	46	3	16
			4	91	11	25
			6	137	20	33
			8	183	32	40
125	0,0123	0,0104	2	75	2	14
			4	150	8	23
			6	224	15	32
			8	299	25	39
160	0,0201	0,0177	2	127	1	11
			4	255	3	14
			6	382	7	24
			8	510	12	32
200	0,0314	0,0284	2	204	1	12
			4	409	3	17
			6	613	8	29
			8	818	15	37
250	0,0491	0,0453	2	326	1	3
			4	653	2	8
			6	979	2	15
			8	1305	4	20
315	0,0779	0,0732	2	527	1	4
			4	1054	2	10
			6	1580	3	18
			8	2107	5	26